

Disassembly and Repair of Type PT Joints – 2000 Series

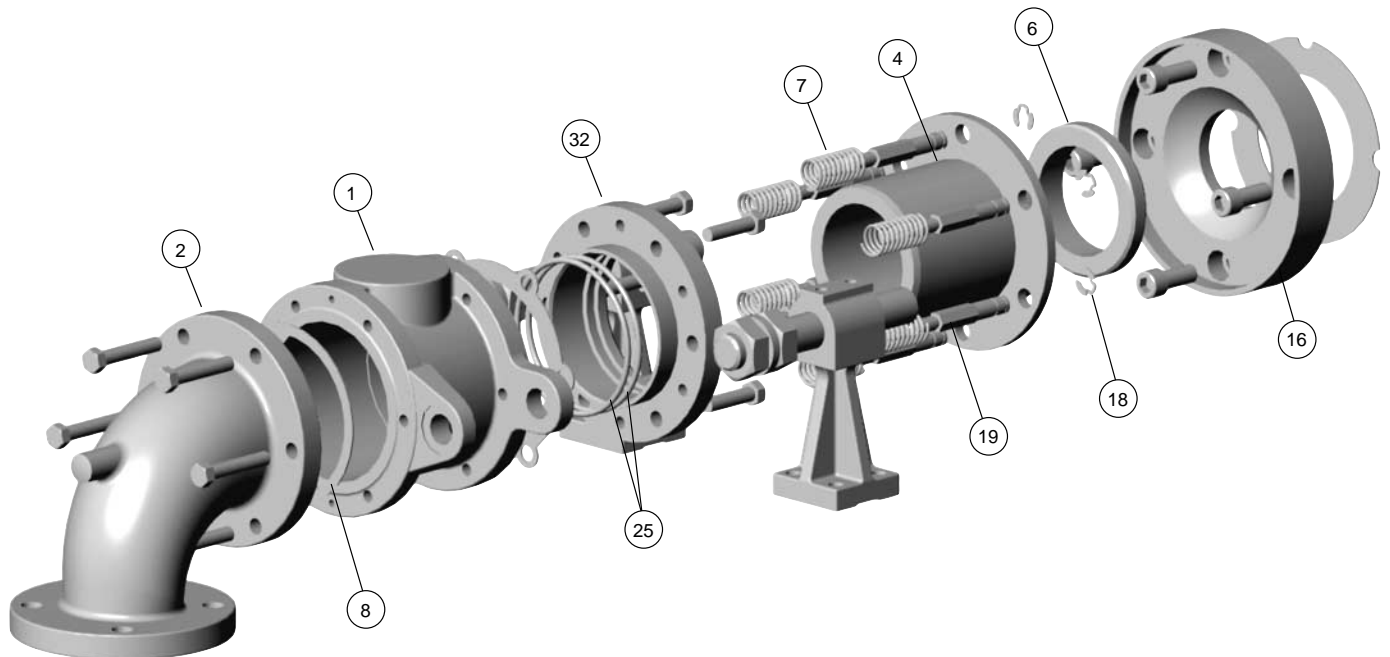

Type LAFY-PT

Item #	Qty	Description
6	1	Carbon Seal
7**	*	Spring
8	1	Gasket
18	*	Retainer Ring
25	2	O-Ring
CSS800-01	1	Silicone Lube

*Quantity varies with joint sizes.

NOTE: Follow your company's safety procedures whenever working on Kadant Johnson rotary joints.

REMOVAL:

STEP 1.

Close the inlet and outlet valve and lock out drive motors.

STEP 2.

Disconnect head casting (2).

STEP 3.

Loosen and unscrew jam nuts A & B on each support rod.

STEP 4.

Slide the joint out away from the journal flange. Be prepared to catch carbon seal ring as it will be free to fall out.

STEP 5.

Remove the end cap assembly (32) from the body (1) by removing the hex head cap screws.

STEP 6.

Remove the nipple (4) from the end cap (32) by placing the assembly into a press with the nipple sealing (flat) surface facing up. Protect the nipple's sealing surface from damage. Push the nipple into the end cap far enough to remove the retainer rings (18), avoid compressing the springs to a solid height. Release the press and the nipple can be removed.

STEP 7.

Remove the o-rings (25) from the end cap or nipple. Clean and inspect the o-ring grooves, the gasket surfaces and the bore of the end cap. Replace if end cap is damaged.

STEP 8.

Inspect the nipple for wear. The flat face of the nipple must be smooth and not scored. Clean the nipple and inspect the area where the o-rings ride. Replace if damaged.

STEP 9.

Install two new o-rings in end cap (32) and lubricate with silicone grease.

STEP 10.

Examine the springs (7) on the end cap. If the springs have taken a slight set and are shorter in length than a new spring, they may still be reused. However, if springs have been compressed to a solid height, they must be replaced.

STEP 11.

Lubricate o-ring surface of the nipple with silicone grease. With the press, push the nipple into the bore of the end cap while aligning it with the spring guide pins (19). Once the nipple flange passes by the spring guide pins, install the retainer rings (18). Release the press.

STEP 12.

Clean the gasket surfaces on the body (1). Place a new gasket on the end cap side of the body. Attach the end cap assembly (4, 32, 25, 7 & 18) to the body using hex head cap screws.

STEP 13.

Inspect wear plate (16) for wear or damage and replace if necessary.

REINSTALLATION

STEP 14.

Using a new carbon seal (6) reinstall the rotary joint over the supports rods. With adjusting nuts A and B move the joint housing in until setup dimension (X) is achieved.

The dimension varies with joint size. Refer to the Kadant Johnson assembly drawing for your particular rotary joint. Once set, lock nuts A & B together.

STEP 15.

With a new gasket (8) reattach head casting (2). Open the line valve and the joint is ready for service.

Periodically monitor carbon seal wear by observing the distance between the retainer rings on the pins and the nipple flange that they pass through. When completely worn the nipple flange will be against the retainer rings.

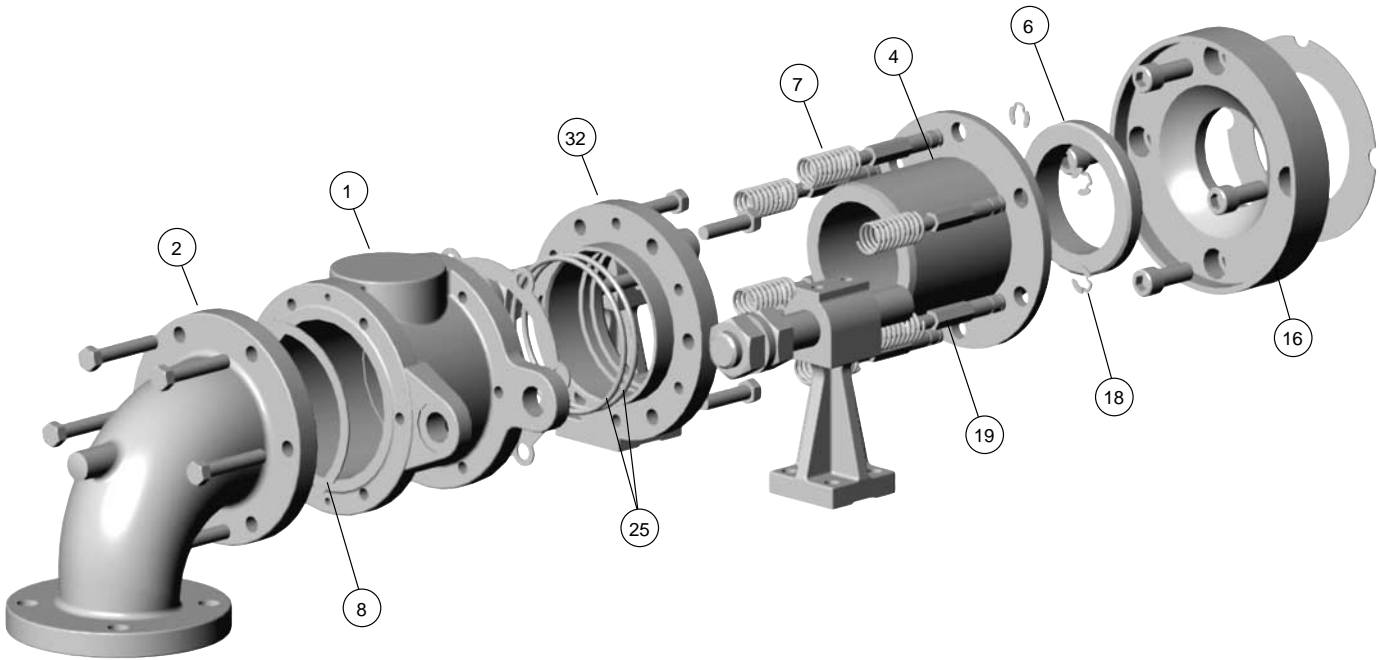
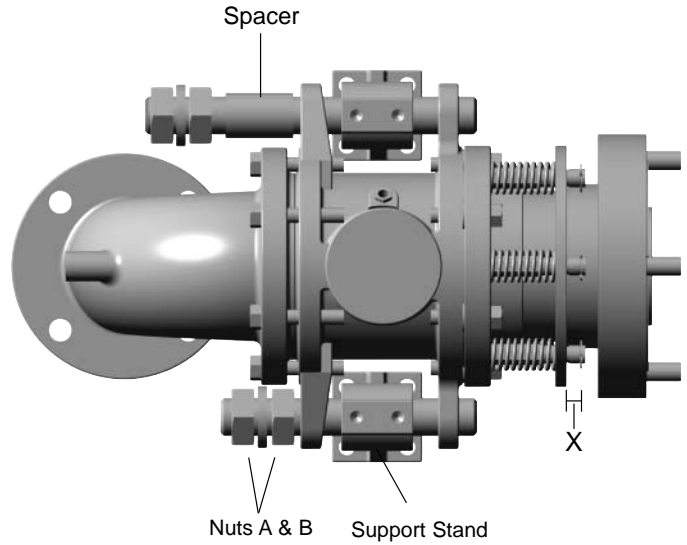

The Kadant Johnson Warranty

Kadant Johnson products are built to a high standard of quality. Performance is what you desire: that is what we provide. Kadant Johnson products are warranted against defects in materials and workmanship for a period of one year after date of shipment. It is expressly understood and agreed that the limit of Kadant Johnson's liability shall, at Kadant Johnson's sole option, be the repair or resupply of a like quantity of non-defective product.



www.kadantjohnson.com